



CONCRETE DISTRIBUTORS

with
HYDRAULIC BOOM

B

Series
B 212+3
B 312+3
B 15+3
B 17+3
B 18+3
B 21+3

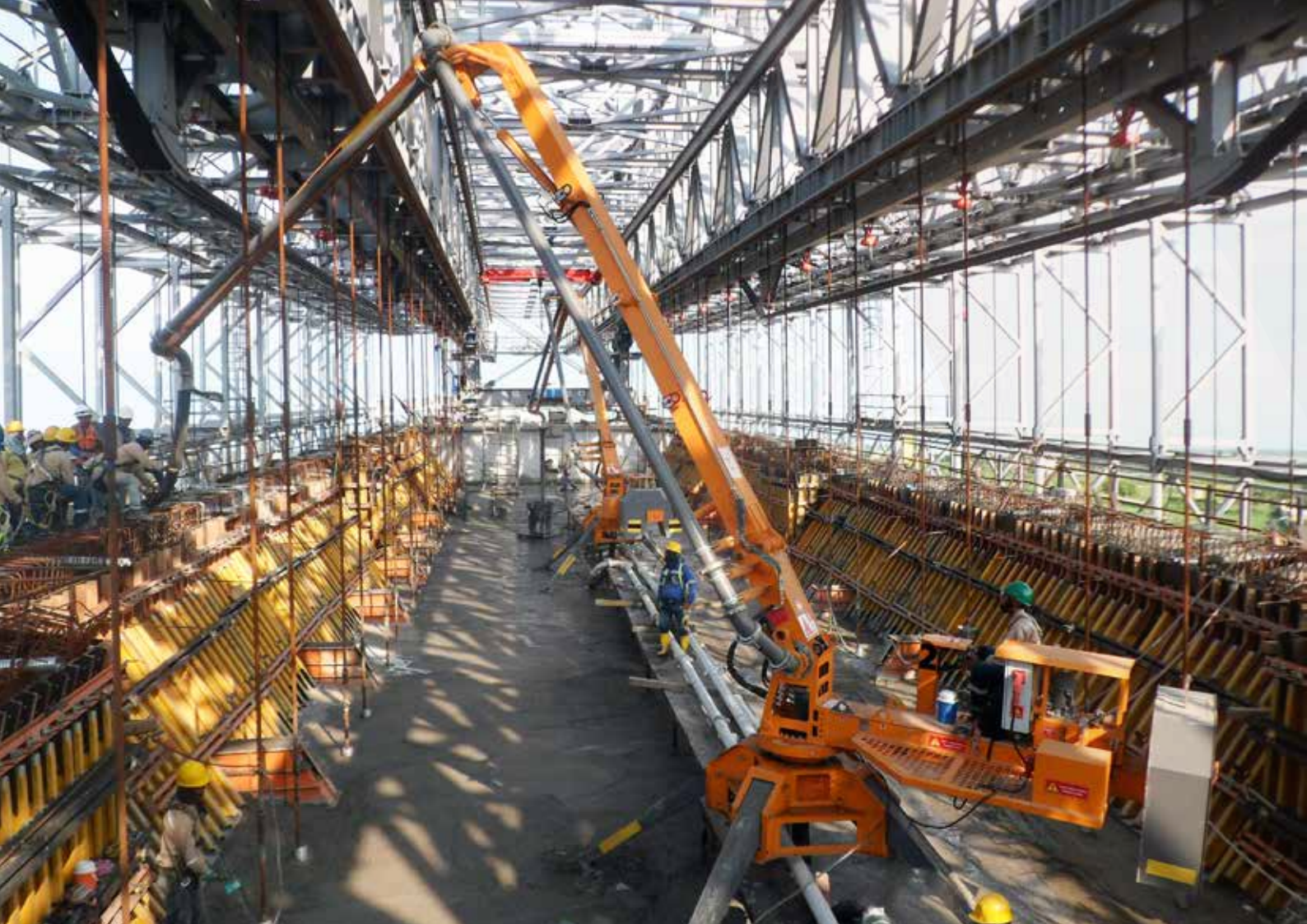

Ultra Light!

ThyssenKrupp



ULTRA LIGHT design hydraulic placing booms are made of **High Strength Steel** which provides long life, light weight and practical use. Distribution area / weight – feet clearance rates are unbeatable. Optimization in the design is to maximize the practicability. Therefore the users describe the equipment as “job-site friendly equipment”.

TWIN DRIVE enables users to alter the power source. In case of electric cut-off, concrete placing can continue without interruptions and short term works can be finished practically. Cost, time and performance gain is achieved at serious levels in construction sites.

BOOM CONSTRUCTION

Produced from special quality steel with high strength, flexibility and suitability for welding. It is light, strong and long durability...

SPLIT FRAME (Detachable Boom Unit)

Simplified split system makes it possible to detach the boom unit easily. When the crane capacity is limited the detachable boom and chassis can be lifted and moved separately.

B 212, B 312, B 15, B 17, B 18

Overall Dimensions

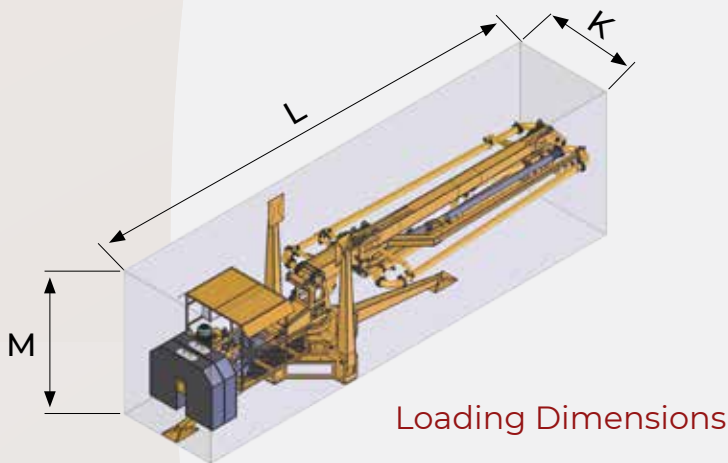
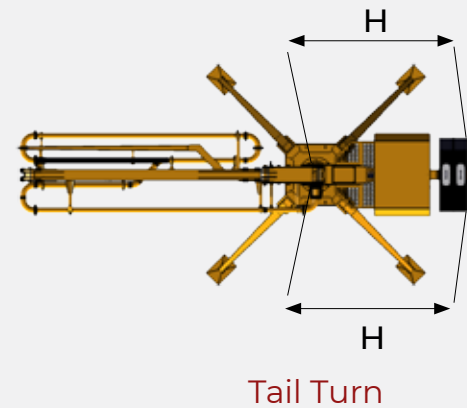
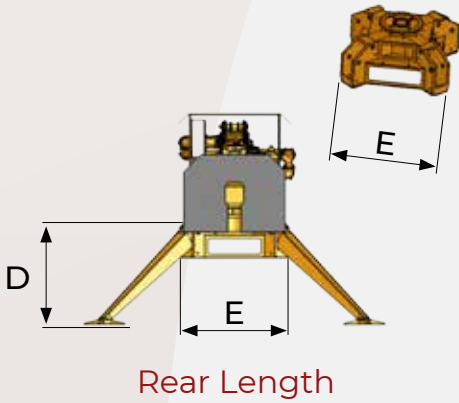
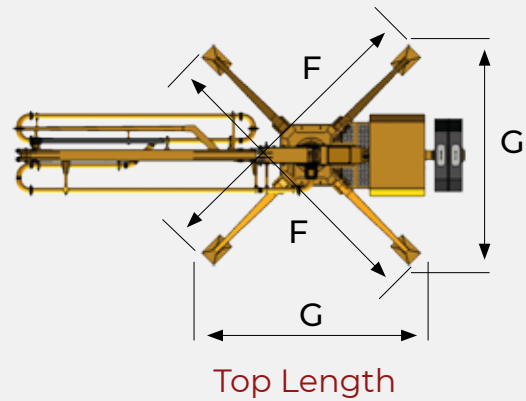
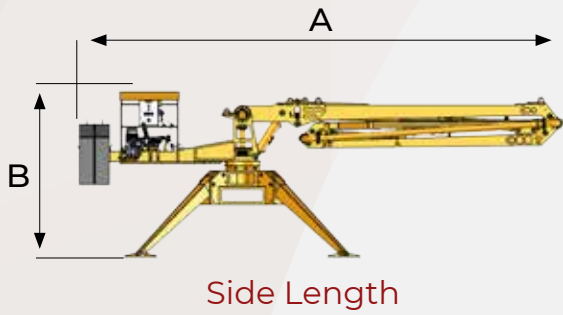

!!! Widely used in high-rise building constructions for casting concrete on wide deck buildings and especially in columns and walls.

Models	B 212	B 312	B 15	B 17	B 18
A	9774 mm	8016 mm	9365 mm	10130 mm	10760 mm
B	2958 mm	2958 mm	3289 mm	3428 mm	3428 mm
C	1878 mm	1878 mm	2359 mm	2346 mm	2346 mm
D	1613 mm	1613 mm	1750 mm	1500 mm	1500 mm
E	1455 mm	1455 mm	1684 mm	1793 mm	1793 mm
F	5187 mm	5187 mm	6142 mm	6590 mm	6590 mm
G	3859 mm	3859 mm	4616 mm	4908 mm	4908 mm
H	3284 mm	3273 mm	3398 mm	3499 mm	3598 mm
K	2000 mm	2050 mm	2000 mm	2050 mm	2050 mm
L	9900 mm	8100 mm	9450 mm	10250 mm	10900 mm
M	2800 mm	2800 mm	3220 mm	3300 mm	3300 mm

B 212, B 312, B 15, B 17, B 18

Weights

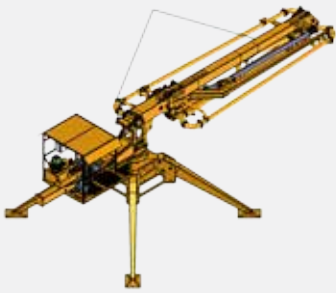

Chassis + Split Boom

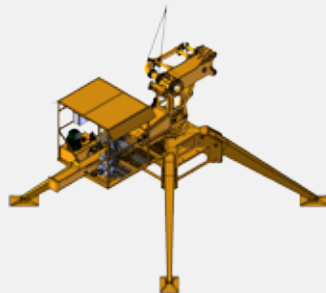

Chassis



Split Boom

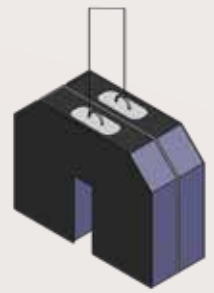

Ballast

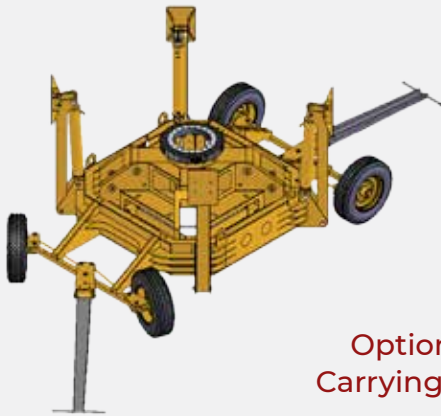

Optional
Carrying Cart



Optional
Elevation Tower

Models	Chassis + Split Boom	Chassis	Split Boom	Ballast
B 212	2210 kg	1310 kg	900 kg	1 X 1260 kg
B 312	2360 kg	1330 kg	1030 kg	1 X 750 kg
B 15	3030 kg	1800 kg	1230 kg	1 X 1000 kg
B 17	3520 kg	1980 kg	1540 kg	2 X 1300 kg
B 18	3600 kg	2060 kg	1540 kg	2 X 1300 kg

B 212, B 312, B 15, B 17, B 18

Technical Details

Models	B 212	B 312	B 15	B 17	B 18
Distribution Diameter	24 m	24 m	30 m	35 m	36 m
Distribution Area	452 m ²	460 m ²	730 m ²	962 m ²	1020 m ²
Chassis Weight	1310 kg	1330 kg	1800 kg	1980 kg	2060 kg
Split Boom Weight	900 kg	1030 kg	1230 kg	1540 kg	1540 kg
Machine Weight (Chassis + Split Boom)	2210 kg	2360 kg	3030 kg	3520 kg	3600 kg
Ballast Weight	1260 kg	1500 kg (2 X 750 kg)	2000 kg (2 X 1000 kg)	2600 kg (2 X 1300 kg)	2600 kg (2 X 1300 kg)
1. Boom Length	6475 mm	4665 mm	5640 mm	6432 mm	7360 mm
2. Boom Length	5525 mm	3718 mm	4700 mm	5503 mm	5503 mm
3. Boom Length	----	3178 mm	4700 mm	5237 mm	5237 mm
End Hose Length	3 m	3 m	3 m	3 m	3 m
Hydraulic Pump Motor	3 kW 3 Phase 380-400 V.	3 kW 3 Phase 380-400 V.	5.5 kW 3 Phase 380-400 V.	7.5 kW 3 Phase 380-400 V.	7.5 kW 3 Phase 380-400 V.
Hydraulic Tank Capacity	60 liter	60 liter	60 liter	80 liter	80 liter
Maximum System Pressure	200 bar	200 bar	200 bar	200 bar	200 bar
Folded Transport Length	9900 mm	8100 mm	9450 mm	10250 mm	11180 mm
Folded Transport Width	2000 mm	2050 mm	2000 mm	2050 mm	2050 mm
Folded Transport Height	2800 mm	2800 mm	3220 mm	3300 mm	3300 mm



Emergency Hand Pump

Remote Control



Elevation Tower



B 21

Technical Details

Model	B 21
Distribution Diameter	24 m
Distribution Area	452 m ²
Chassis Weight	1310 kg
Split Boom Weight	900 kg
Machine Weight (Chassis + Split Boom)	2210 kg
Ballast Weight	1260 kg
1. Boom Length	6475 mm
2. Boom Length	5525 mm
3. Boom Length	----
End Hose Length	3 m
Hydraulic Pump Motor	3 kW 3 Phase 380-400 V.
Hydraulic Tank Capacity	60 liter
Maximum System Pressure	200 bar
Folded Transport Length with Tail	9900 mm
Folded Transport Length Unassembled Tail	2000 mm
Folded Transport Width	2800 mm
Folded Transport Height	3650 mm

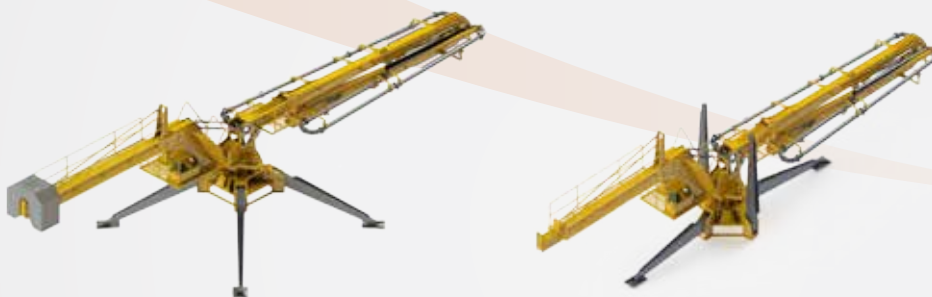
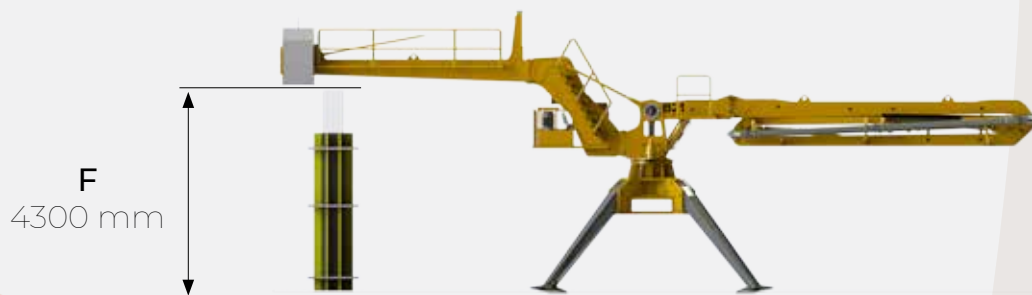
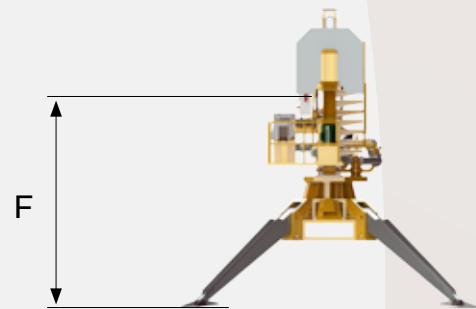
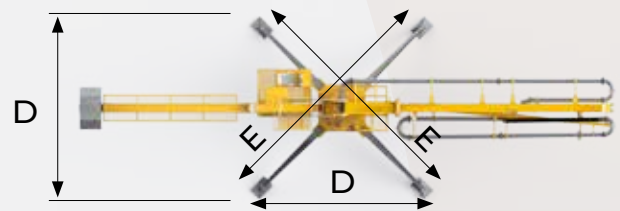
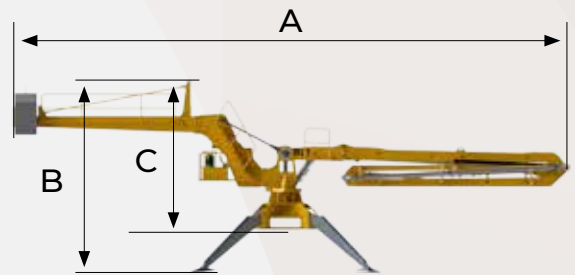

Models	B 21
A	15900 mm
B	5850 mm
C	4300 mm
D	5050 mm
E	6750 mm
F	4300 mm

B 212, B 312, B 15, B 17, B 18, B 21

Concrete Scatter Diagrams

B 212

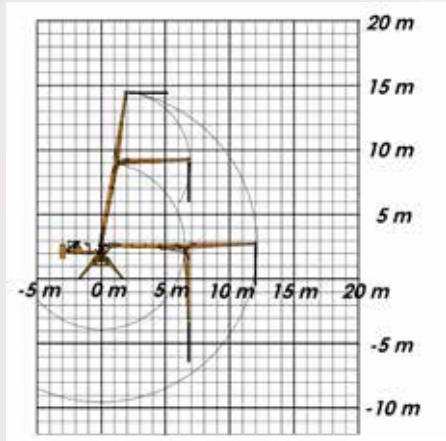

B 312

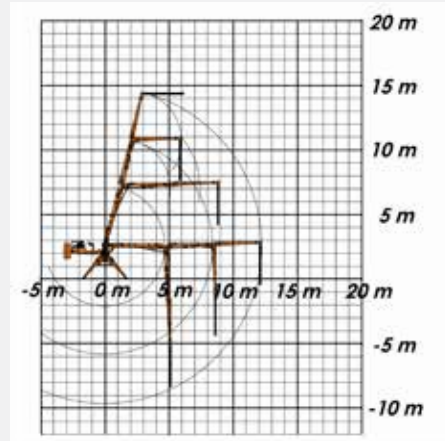

B 15

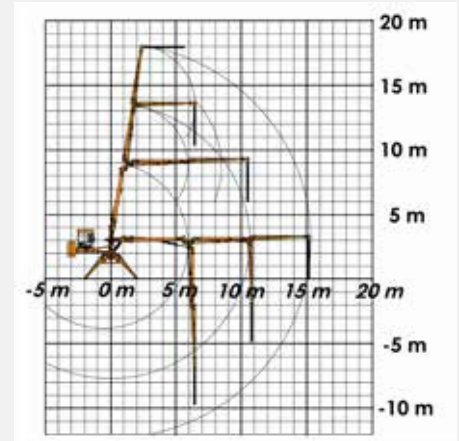

B 17

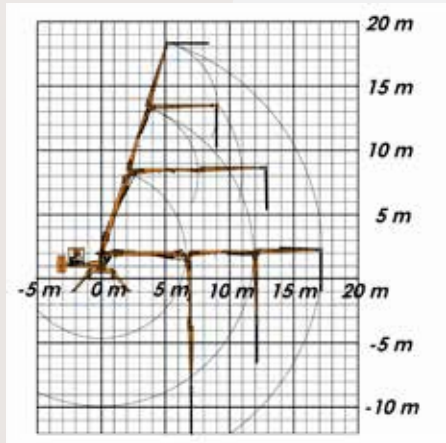

B 18

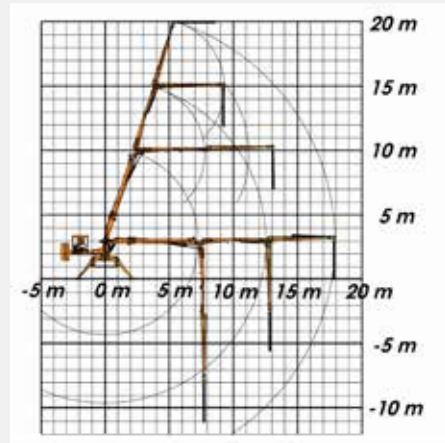

B 21

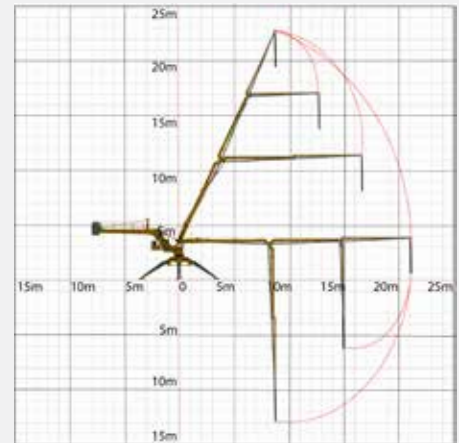

*“Art Of
Concrete Placing...”*



www.atabeymakina.com

Address: Keresteciler San. Sit. 4. Cad. No: 39 Kahramankazan / Ankara - TURKEY

Phone: +9 0312 441 11 33 Fax: +9 0312 441 58 88